



## Specialized Motor Drives

The Mooring Capstan Controller for the Virginia Class Submarines demonstrates EMS's capability to supply specialized variable-speed drives to meet the particular demands of the submarine environment: non-standard control and feedback requirements, integrated ancillary functions, highly detailed hardware and software ILS requirements.

It achieves this through a modular design featuring scalable, configurable building blocks, suitable across a wide range of ratings, applications and motor types, and EMS's long association with submarine requirements.

This application highlights the power engineering, digital control and mechanical

design expertise required for the design of specialized motor drives:

Accurate speed/torque control, with maximum efficiency, is implemented by generating a field-oriented excitation of the Permanent Magnet Synchronous Motor, using a custom microprocessor application and an IGBT 3-phase PWM inverter.

A multi-phase transformer front-end ensures compliance with Mil-Std 1399-300A while helping to limit EMI emissions.

These main elements are integrated into a compact and rugged, hard-mounted enclosure.

### Features:

- **Field-Oriented Vector control of AC Motor**
- **Multiphase Transformer Rectifier front end draws sinusoidal current: very low distortion of input supply**
- **Fully EMI-compliant to Mil-Std-461F**
- **Status & Diagnostic LCD Display**
- **Built-in Motor Insulation Resistance Measurement function**
- **Adaptable design techniques, hardware and software building blocks**

# Specialized Motor Drives: Capstan Controller

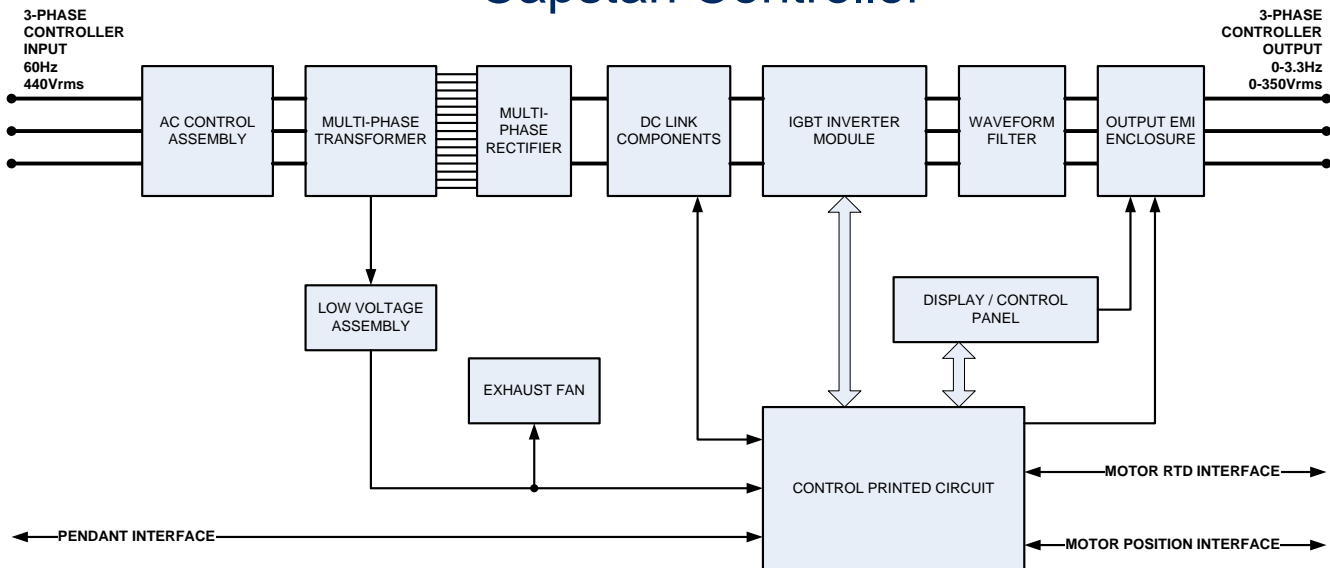

## Technical Specifications:

<i>Dimensions:</i>	Height = 36" x Width = 20" x Depth = 15"
<i>Weight:</i>	455 lb
<i>Input Supply Voltage:</i>	440VAC, 60Hz, 3-phase, 3-wire, ungrounded
<i>Variable Voltage, Variable Frequency Output</i>	343V at 3.3Hz for rated speed & torque Speed controllable down to hold at standstill Max holding torque = 200% of rated torque
<i>Rating:</i>	10 HP
<i>Input Supply Current Harmonics:</i>	Less than 5% THD
<i>Enclosure:</i>	45° Drip-Proof
<i>Operating Temperature:</i>	4 to 40°C ambient
<i>Humidity:</i>	0 to 95% RH
<i>Cooling Interface:</i>	Forced air cooled
<i>Electrical Interfaces:</i>	Remote Pendant; 6 x Motor Temperature Sensors; Motor Position Feedback.
<i>Shock:</i>	Mil-S-901D, Medium Weight, Grade B, Class I, Type A, Base-Mounted,
<i>Vibration:</i>	MIL-STD-167-1
<i>Electromagnetic Interference:</i>	Mil-Std 461-F, Submarines



**Ultra Electronics**  
 EMS Development Corporation  
 95 Horseblock Road, Unit 2  
 Yaphank  
 New York 11980  
 USA  
 Tel: +1 631 345 6200  
 Email: [information@ultra-ems.com](mailto:information@ultra-ems.com)  
[www.ultra-ems.com](http://www.ultra-ems.com)  
[www.ultra-electronics.com](http://www.ultra-electronics.com)

Cleared for open publication on 07/03/13  
 Office of Security Review  
 US Department of Defense

Ultra Electronics reserves the  
 right to vary these specifications  
 without notice.  
 © 2019 EMS Development Corporation